



# Suva<sup>®</sup>

refrigerants

**Note:** This publication supersedes Bulletin ART-12.

**ART-27**

## Suva<sup>®</sup> 134a (HFC-134a) for Mobile Air Conditioning

### Introduction

In the past almost all mobile air conditioning (a/c) systems used CFC-12 (R-12) as the refrigerant. This included cars, vans, light and heavy trucks, as well as some buses and off-highway construction and farm equipment. Scientists have found evidence that CFC products (including CFC-12) are a primary cause of depletion of the earth's protective ozone layer. HFC-134a has been chosen to replace CFC-12 in new mobile a/c systems.

**NOTE: Refer to DuPont Bulletin P-134a for additional technical information on HFC-134a.**

### Transition to HFC-134a

HFC-134a is the worldwide choice to replace CFC-12 in mobile a/c for *new vehicles*. Because it contains no chlorine, it has a zero ozone depletion potential. To optimize the performance of HFC-134a in new a/c systems, many of the components have been redesigned. These include lubricants, compressor, desiccant, hoses, evaporator, and condenser. A worldwide transition to HFC-134a systems in new vehicles began in 1991 in certain European vehicles. All new North American, Japanese, and European vehicles are now made with HFC-134a systems.

### Suva<sup>®</sup> 134a Availability from DuPont

DuPont markets Suva<sup>®</sup> 134a directly to vehicle manufacturers (OEMs) and the North American automotive aftermarket. Outside the U.S., DuPont Suva<sup>®</sup> 134a and other Suva<sup>®</sup> refrigerants are supplied through our vast, worldwide network of refrigerant distributors. DuPont currently has more than 150 distributors located in almost 130 countries throughout the world. This network is supported by DuPont personnel in regional offices located in Japan, Europe, Canada, Mexico, South America, Australia, and the Asia Pacific region, as well as corporate headquarters in Wilmington, DE. See the list on the back cover of this bulletin for information on how to order DuPont refrigerants.

### Safety Considerations—HFC-134a

Because the physical and chemical properties of HFC-134a are very similar to CFC-12, most of the same safety considerations apply for HFC-134a. Refer to DuPont Bulletin—Safety of Suva<sup>®</sup> Refrigerants (H-27350-4) for details.

There is one important difference between the two materials. Both are nonflammable at ambient temperature and atmospheric pressure. However, tests under controlled conditions have indicated that, at pressures above atmospheric and with air concentrations greater than 60% by volume, HFC-134a can form combustible mixtures. (An ignition source is required to initiate combustion. In this regard, the product behaves in a similar manner to HCFC-22, which is nonflammable, but also combustible at pressures above atmospheric in the presence of high air concentrations. The tests indicate that HFC-134a can undergo combustion at lower pressures than HCFC-22.)

**Under no circumstance should any Bulk Storage, Cylinder Filling, Equipment Charging, or Refrigerant Reclaim or Recovery System or any a/c or refrigeration system be pressure tested with air/HFC-134a mixtures.**

## Overview of the HFC-134a Mobile a/c System

What changes have been made to the basic a/c system? To the average car owner, the system looks the same. However, there have been some important changes made internally to ensure good performance and reliability. The most significant change is with the lubricant. CFC-12 systems use mineral oils; this type of oil is not suitable for HFC-134a because of poor miscibility. This causes poor oil circulation and would lead to premature compressor failure due to lack of lubrication. HFC-134a systems employ new synthetic lubricants from the polyalkylene glycol (PAG) family. This material is compatible with the new system components and has acceptable miscibility and very good thermal stability. Due to higher bearing loads in the compressor because of a higher compression ratio, bearings in certain types of compressors have been redesigned. Also, due to the different chemical and physical properties of HFC-134a, the internal configuration of the compressor may be changed slightly to improve performance. HFC-134a has a higher vapor pressure than CFC-12 at condensing temperatures; therefore, condensing capacity has been increased to minimize the increase in compressor discharge pressure. This has been done by either increasing the capacity of the condenser itself or improving air flow through the condenser by increasing fan capacity or adding air baffles to

prevent hot air from the engine compartment passing through the condenser. As a result of these design changes, the HFC-134a system discharge pressure could be the same as that for CFC-12, to as much as 10% higher. Actual pressure will depend on system design and operating conditions. A desiccant (or drying agent) in the form of molecular sieve beads is used in the system to remove small amounts of moisture. Because HFC-134a is more chemically reactive with the desiccant currently used with CFC-12, a new type of desiccant is being used. Consult your desiccant (drier) supplier for their recommendations.

Another goal of the design engineers was to reduce refrigerant emissions from the system. This has been accomplished by using hoses that are less permeable with HFC-134a. Most of these hoses contain a thin layer of nylon to act as the permeation barrier. Redesigning the compressor shaft seal and connections throughout the system has also reduced leakage.

## Service Fittings for HFC-134a System

To avoid cross-contamination of CFC-12 and HFC-134a when servicing a/c systems, the Society of Automotive Engineers (SAE) has adopted special fittings for use with HFC-134a. The high and low pressure service valves for existing CFC-12 and new HFC-134a systems are shown in **Figure 1**. Also shown are the refrigerant cylinder outlet fittings for CFC-12 and HFC-134a.

**NOTE: For HFC-134a refrigerant cylinders and a/c service equipment, refer to SAE Standards J639 and J2197 for additional details.**

## Retrofit to R-134a

As of mid-1996 there are approximately 90 million vehicles in operation in the U.S. that use CFC-12 in their air conditioning systems. The U.S. Clean Air Act required that all CFC-12 production cease on December 31, 1995. It is reasonable to assume that a significant portion of the existing fleet will require retrofit to R-134a at some time during their remaining life. **The automobile original equipment manufacturers (OEMs) and component suppliers have selected HFC-134a as their retrofit refrigerant of choice.** They are the best source of retrofit information and should be consulted for specific questions.

**Figure 1. Service Fittings for CFC-12 and HFC-134a Systems**

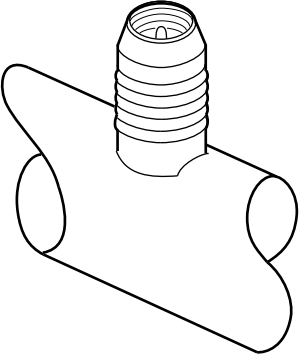
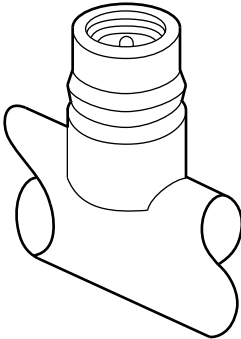
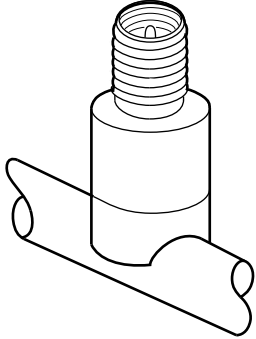
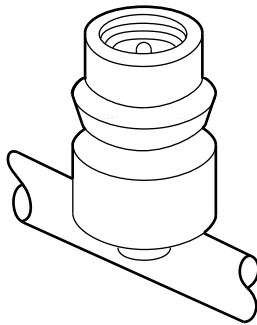
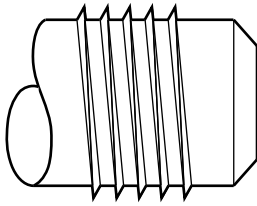
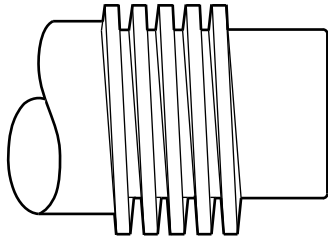
CFC-12 Components	HFC-134a Components
<b>Low Pressure Service Valve</b>	
<p>Threads: 7/16"–20, also known as "1/4" flare"</p> 	 <p>Quick connect coupler; internal threads are optional</p>
<b>High Pressure Service Valve</b>	
<p>Threads: 3/8"–24</p> 	 <p>Quick connect coupler; internal threads are optional</p>
<b>Refrigerant Cylinder Outlet Fitting</b>	
 <p>Threads: 7/16"–20; also known as "1/4" flare"</p>	 <p>Threads: 1/2" ACME</p>

The current position of the U.S. automobile OEMs:

- Use R-12 (of known quality) as long as it is available.
- If R-12 is unavailable or you choose to retrofit, use only HFC-134a and PAG lubricant.
- Follow recommended procedures for the specific vehicle.

In some cases where extensive system repair is required, retrofit may be an economical option because the incremental cost to retrofit would be minimal and performance could be ensured.

## **Materials Compatibility—New Vehicles**

### **Hose Selection**

As with CFC-12, proper hose selection is one key to the performance and customer satisfaction of HFC-134a systems. Several factors must be considered when selecting hose materials: flexibility, refrigerant permeation, moisture ingress into the a/c system, noise transmission, fitting integrity, and chemical compatibility. All of these factors must be evaluated over a wide range of temperatures and pressures, both within the a/c system and the underhood conditions. Nylon composite or nylon barrier hoses, as well as several different types of nitrile hoses, are currently used in CFC-12 systems. The permeation rate of HFC-134a through certain types of nitrile hoses is higher than that of CFC-12. For this reason, many companies in the mobile a/c industry have selected nylon composite or nylon barrier hoses for use with HFC-134a. These hoses provide a good balance of the properties mentioned above.

There are several different types of hose construction. Nylon composite hoses typically have a thin nylon inner liner that acts as the permeation barrier. This inner liner is then covered with a nylon reinforcement layer for strength. The outer layer is made of chlorobutyl rubber to minimize moisture ingress into the a/c system. Depending on the particular hose design, there could be additional layers or other materials of construction to provide the proper balance of desired properties.

Nylon barrier hoses also use a thin nylon layer to prevent refrigerant permeation. However, they also contain a nitrile or chloroprene (also known as neoprene) liner inside the nylon, which aids in applying hose fittings. As with the nylon composite hose construction, there are many different hose designs used to provide the best balance of properties.

### **Elastomer Compatibility**

Elastomers are used in all mobile a/c systems as seals, gaskets, O-rings, and for construction of hoses. Tests of several commonly used elastomers with CFC-12/mineral oil and HFC-134a/PAG have been performed to determine relative compatibility.

The selection of O-ring materials depends on the OEM design parameters. For HFC-134a systems, the following are some of the products that will be used:

- Neoprene W
- Neoprene WRT
- Highly saturated nitrile rubber (HNBR)

Nitrile rubber (NBR) and EPDM may also be used in certain applications.

### **Desiccant Compatibility**

New desiccants are required with HFC-134a. Several desiccant suppliers have products available and should be consulted for their recommendation.

### **Lubricant Selection**

There are many criteria to consider when selecting a lubricant for use with HFC-134a. Some of the most important are: lubricity, miscibility, chemical stability, materials compatibility, and tolerance to contaminants. Almost all of the mobile OEMs and compressor manufacturers have selected PAGs for their equipment. These PAGs are provided by various lubricant suppliers and will come in a range of viscosities (about 60 to 135 cSt) with different additive packages. Additives are normally added to the base lubricant to enhance various properties such as lubricity or thermal stability. It is important to remember that the individual OEMs and compressor manufacturers will recommend specific lubricants for their products.

Existing mobile a/c mineral oils (500 SUS viscosity or 100 cSt at 40°C [104°F]) are completely soluble in CFC-12 over a wide temperature range. This ensures that the oil moves freely around the system and returns to the compressor at a rate sufficient to provide acceptable lubrication. Many of the PAGs used in mobile a/c systems are not completely miscible with HFC-134a.

Even though PAG/HFC-134a is less miscible than mineral oil/CFC-12, tests and operating experience have demonstrated that this partial miscibility is acceptable for mobile a/c. However, in parts of the system that operate above the minimum solubility temperature and at certain lubricant/refrigerant ratios, two phases will occur and the lubricant rich portion might collect at these locations. This could cause flow restrictions if the system is not properly designed. Individual system testing is required to determine the impact that partial miscibility might have on system performance and compressor durability.

### Compatibility Concerns if HFC-134a and CFC-12 Are Mixed

As mentioned earlier, unique fittings have been developed for HFC-134a mobile a/c systems, containers, and service equipment. This has been

done to avoid mixing CFC-12 and HFC-134a during vehicle servicing. There are a number of reasons for this.

### Effect on Compressor Discharge Pressure

HFC-134a and CFC-12 are chemically compatible with each other; this means that they do not react with each other and form other compounds. However, when the two materials are mixed together, they form what is known as an “azeotrope.” An azeotrope is a mixture of two components that acts like a single compound, but has physical and chemical properties different than either of the two components. An example of this is Freon® 502, which is an azeotrope of HCFC-22 and CFC-115. It has a different vapor pressure, energy efficiency, etc., than either HCFC-22 or CFC-115. When CFC-12 and HFC-134a are mixed, they form a “high pressure azeotrope.” This means that the vapor pressure of the azeotrope is higher than that of either of the two components by themselves. **Figure 2** estimates how the compressor discharge pressure changes depending on how much CFC-12 is mixed with HFC-134a.

**Figure 2. Effect of Increasing Concentrations of CFC-12 in HFC-134a on Compressor Discharge Pressure (Condenser at 79°C [175°F]; evaporator at 4.5°C [40°F])**

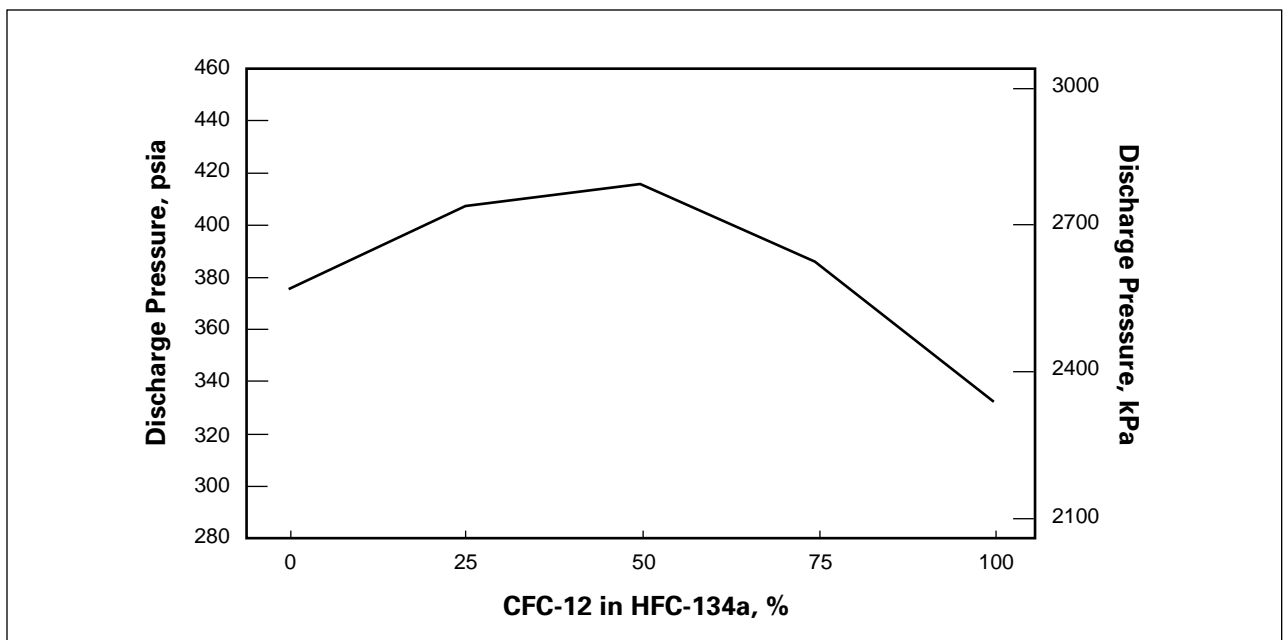

Another characteristic of an azeotrope is that it is very difficult to separate the components once they are mixed together. A refrigerant recycle or recovery machine will *not* be able to separate mixtures of HFC-134a and CFC-12. Such mixtures will usually have to be disposed of by incineration.

**NOTE: SAE has determined that 2% residual CFC-12 in a system retrofit to HFC-134a should not cause performance or compatibility problems. However, the residual CFC-12 should be reduced as much as possible.**

## Concerns when Mixing Other Refrigerants

For the past 50 years, the automotive a/c industry has used only CFC-12. Cross-contamination of refrigerants has never been a problem. During the transition from CFC-12 to HFC-134a, there will be at least two refrigerants in most shops. In addition, other refrigerants are showing up in the marketplace. Caution must be used to avoid mixing refrigerants, both for performance and safety considerations. EPA regulations *require* unique fittings, labels, and recovery/recycle equipment for each refrigerant used for mobile a/c systems.

### Why Not Use HCFC-22 in Your Car?

The following are a few reasons why HCFC-22 should not be used in mobile a/c systems:

- *High discharge pressure:* At 35°C (95°F) condensing temperature, the vapor pressure of CFC-12 is 123 psig (951 kPa); HCFC-22 pressure is 182 psig (1357 kPa). At 79°C (175°F), the CFC-12 pressure is 316 psig (2280 kPa); the HCFC-22 pressure is 511 psig (3624 kPa).
- *Hose permeation:* It has been demonstrated many times in lab and field tests that HCFC-22 permeates rapidly through most types of hoses currently in use.
- *Condensing capacity:* The condensers on most cars are too small for HCFC-22.
- *Seal, O-ring compatibility:* HCFC-22 when used by itself is much more aggressive to existing seal and O-ring materials than CFC-12. Leaks at O-rings and shaft seals after extended use are very probable.

### Mixtures of CFC-12 and HCFC-22

The real problem with mixing CFC-12 and HCFC-22 is high pressure. Using the same scenario as above, the CFC-12 discharge pressure would be 316 psig (about 2280 kPa) at a condensing temperature of 79°C (175°F). With just 20% HCFC-22 added to the system, the pressure increases to 396 psig (2830 kPa); another 20% and it increases to 443 psig (3155 kPa). In a system that normally contains two pounds of CFC-12, 20% is only about six ounces.

The other major problem with this mixture is that it is very difficult to separate the components. They *can't* be separated by a recycle or recovery machine. Many CFC-12 recycle machines have automatic vents to purge the noncondensibles; they are activated if the pressure of the CFC-12 is higher than the normal vapor pressure by a certain amount (this is normally an indication that excess air is present). As mentioned above, when HCFC-22 is mixed with CFC-12, the vapor pressure is higher than CFC-12 by itself. Depending on the amount of HCFC-22 in the mixture, it will probably have high enough pressure to activate the automatic vent.

**NOTE: A similar problem can occur when CFC-12 and HFC-134a are mixed.**

### What about Mixing Flammable Refrigerants with CFC-12 or HFC-134a?

The automobile OEMs as well as the U.S. EPA, SAE, IMACA, and MACS do *not* endorse the use of flammable refrigerants. DuPont supports this position. The automotive industry has been using nonflammable refrigerants for nearly 50 years, and the industry is simply not prepared to handle flammables. The concern goes far beyond charging refrigerant into a car's system. There are hazards associated with many aspects: packaging, shipping, storage and handling, venting, underhood leaks, leaks into the passenger compartment, and so on. Flammable materials can be handled safely, but, systems and service equipment must be designed for this, procedures must be developed, and hundreds of thousands of service people must be trained.

Propane is a flammable material that many of us are familiar with in barbecue grills. Unfortunately it sometimes finds its way into car a/c systems. This can present a real safety problem for the car owner as well as the shop that services the a/c system. With refrigerant recycling, the propane can also contaminate the shop's CFC-12 and HFC-134a supply.

It is well known that propane by itself is flammable. What isn't so well known is that it only takes about 10% propane in CFC-12 to make the mixture flammable. It's worse with HFC-134a; it would take only about 5% propane. In an a/c system that normally contains two pounds of HFC-134a, just 1-1/2 ounces (42 grams) of propane would make the mixture flammable. Two other flammable materials, butane and isobutane, have flammability properties similar to propane when mixed with CFC-12 or HFC-134a.

There are many good reasons for keeping refrigerants separate and for buying refrigerants from reputable dealers. A reliable supply of good quality CFC-12 or HFC-134a is critical to customer satisfaction and the business success of the automotive a/c service industry. Today's a/c systems are not designed for flammable refrigerants nor is the service industry prepared to handle them.

## Conclusions

- HFC-134a is the refrigerant of choice to replace CFC-12 for new mobile a/c systems. The OEM transition to HFC-134a began in 1991 and is now complete.
- Although the properties of HFC-134a are similar to CFC-12, it is not a "drop-in" replacement for mobile a/c systems nor is any other refrigerant. OEM design modifications have been made to ensure acceptable cooling performance and long-term system durability.
- Shortages of CFC-12 will occur sometime in the next few years, and retrofit to R-134a will be a logical alternative for a significant portion of the CFC-12 fleet.
- Compatibility testing of several commonly used elastomeric materials has demonstrated that suitable materials are available for seals, gaskets, O-rings, and hoses.
- Suitable desiccants are available for use with HFC-134a; consult your supplier for recommendations.
- Certain types of PAGs have been qualified for use with HFC-134a in mobile a/c.
  - Polyol esters are being evaluated as possible "second generation" lubricants and for use in the aftermarket.
- HFC-134a and CFC-12 form a high-pressure azeotrope; this increases compressor discharge pressure significantly.
- HFC-134a/PAG or HFC-134a/POE are very stable. Tests indicate that minimal lubricant degradation occurs when small amounts of chlorinated compounds are present.
- Mixing refrigerants can create safety and performance problems.
- Flammable refrigerants are not recommended for mobile a/c systems. OEMs and component manufacturers recommend using only CFC-12 or R-134a.

**For information on DuPont Suva® 134a (Auto),  
in the U.S., call (800) 235-SUVA**

---

**Outside the U.S., for purchasing and/or technical information,  
contact any of the following:**

---

**Europe**

DuPont de Nemours  
International S.A.  
2 Chemin du Pavillon  
P.O. Box 50  
CH-1218 Le Grand-Saconnex  
Geneva, Switzerland  
41-22-717-5111

**Canada**

DuPont Canada, Inc.  
P.O. Box 2200, Streetsville  
Mississauga, Ontario  
Canada  
L5M 2H3  
(905) 821-3300

**Mexico**

DuPont, S.A. de C.V.  
Homero 206  
Col. Chapultepec Morales  
C.P. 11570 Mexico, D.F.  
52-5-722-1000

**South America**

DuPont do Brasil S.A.  
Alameda Itapicuru, 506  
Alphaville 06400 Barueri  
São Paulo, Brazil  
55-11-421-8509

DuPont Argentina S.A.  
Casilla Correo 1888  
Correo Central  
1000 Buenos Aires, Argentina  
54-1-311-8167

**Pacific**

DuPont Australia  
P.O. Box 930  
North Sydney, NSW 2060  
Australia  
61-2-923-6165

**Japan**

Mitsui DuPont Fluorochemicals  
Co., Ltd.  
Chiyoda Honsha Bldg.  
5-18, 1-Chome Sarugakucho  
Chiyoda-Ku, Tokyo 101 Japan  
81-3-5281-5805

**Asia**

DuPont Taiwan  
P.O. Box 81-777  
Taipei, Taiwan  
886-2-514-4400

DuPont Asia Pacific Limited  
P.O. Box TST 98851  
Tsim Sha Tsui  
Kowloon, Hong Kong  
852-734-5345

DuPont Thailand  
P.O. Box 2398  
Bangkok 10501, Thailand  
66-2-238-4361

DuPont China Ltd.  
Rm. 1704, Union Bldg.  
100 Yanan Rd. East  
Shanghai, PR China 200 002  
Phone: 86-21-328-3738  
Telex: 33448 DCLSH CN  
Fax: 86-21-320-2304

DuPont Far East Inc.  
P.O. Box 12396  
50776 Kuala Lumpur, Malaysia  
Phone: 60-3-232-3522  
Telex: (784) 30391 DUFE M  
Fax: 60-3-238-7250

DuPont Korea Ltd.  
4/5th Floor, Asia Tower  
#726, Yeoksam-Dong,  
Kangnam-Ku  
Seoul, 135-082, Korea  
82-2-721-5114

DuPont Singapore Pte. Ltd.  
1 Maritime Square #07 01  
World Trade Centre  
Singapore 0409  
65-273-2244

DuPont Far East, Philippines  
5th Floor, Solid Bank Bldg.  
777 Paseo de Roxas  
Makati, Metro Manila  
Philippines  
63-2-818-9911

DuPont Far East Inc.  
7A Murray's Gate Road  
Alwarpet  
Madras, 600 018, India  
91-44-454-029

DuPont Far East Inc.—Pakistan  
9 Khayaban-E-Shaheen  
Defence Phase 5  
Karachi, Pakistan  
92-21-533-350

DuPont Far East Inc.  
P.O. Box 2553/Jkt  
Jakarta 10001, Indonesia  
62-21-517-800

---

The information contained herein is based on technical data and tests that we believe to be reliable and is intended for use by persons having technical skill, at their own discretion and risk. Because conditions of use are outside of DuPont control, we can assume no liability for results obtained or damages incurred through the application of the data presented.



**Suva®**  
Only by DuPont