

HL 122

economical receiving and batching

*Portable multi-purpose platform scale.
Simple, durable and economical.
Available in three convenient capacities.*



Avery Berkel

retail and food service weighing solutions

economical receiving and batching

Easy to use, economically priced, and battery powered, these portable, multi-purpose, digital platform scales serve a broad range of retail and industrial applications. Features include adjustable indicator with large LCD display, easy to use operating keys, one-touch weight display, and repeatable tare deduction.

And should service ever be necessary, the HL 122 like all Avery Berkel products, are backed by a nationwide service network.

SPECIFICATIONS

◆ Capacity Options

130 x .05 lb — 60 x .02 kg
330 x .10 lb — 150 x .05 kg
660 x .20 lb — 300 x .10 kg
NOT Legal for Trade

◆ Platform Stainless steel topped.

◆ Weight Display 7 Segment LCD type, 1" (25 mm) height, 6 digit.

◆ Sample Size 10, 20, 50, or 100 pieces selectable with SAMPLE SIZE key.

◆ Operating Temperature 32° to 104° F (0° to 40° C)

◆ Power Requirement AC Adapter, built-in rechargeable battery or 6 'D' cell batteries (Adapter and rechargeable battery included).

◆ Battery Life Up to 480 continuous hours on Alkaline cell batteries. Up to 180 continuous hours on rechargeable battery.

◆ Weight

130 lb & 330 lb capacity models:

Net: 35 lb (18 kg)
Shipping: 42 lb (19 kg)

660 lb capacity model:

Net: 55 lb (25 kg)
Shipping: 62 lb (28 kg)

FEATURES & BENIFITS

- ◆ **Powered by: AC Adapter, built-in rechargeable battery, or 'D' Cell batteries.**
- ◆ **Adjustable indicator that can be column or desktop mounted.**
- ◆ **"One-touch" gross or net weight display.**
- ◆ **Repeatable tare deduction feature.**
- ◆ **Over/Under check weight display.**
- ◆ **Automatic counting function.**
- ◆ **Smooth stainless steel topped platform allows for easy cleanup.**

DIMENSIONS

130 lb & 330 lb capacity models:

A: 20 1/2" (520 mm)
B: 14 1/2" (370 mm)
C: 6 1/4" (160 mm)
D: 11" (278 mm)
E: 8" (204 mm)
F: 6 3/4" (174 mm)
G: 36 1/2" (930 mm)

660 lb capacity model:

A: 23 1/2" (600 mm)
B: 18" (460 mm)
C: 6 1/4" (160 mm)
D: 11" (278 mm)
E: 8" (204 mm)
F: 6 3/4" (174 mm)
G: 36 1/2" (930 mm)

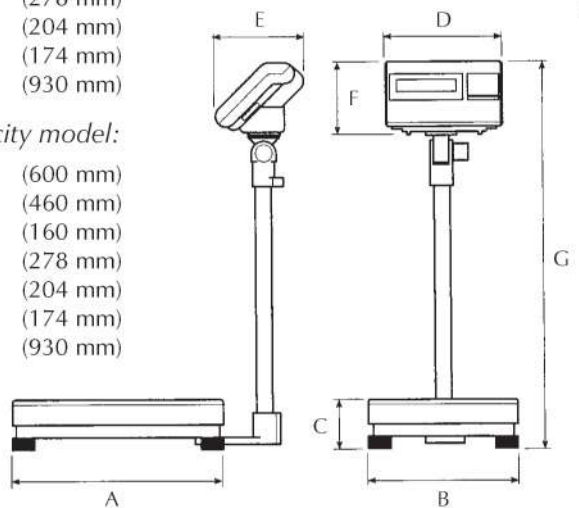

retail and food service weighing solutions

Avery Berkel North America
3133 N 150 E
LaPorte, IN 46350

PH Toll-Free: 800-237-1886
PH: 219-325-9587

FAX Toll-Free: 800-237-2063
FAX: 219-325-9594

sales@AveryBerkelUSA.com
www.AveryBerkelUSA.com



A division of Weigh-Tronix, Inc.
1000 Armstrong Drive
Fairmont, MN 56031, USA



Distribuido por:
Refrigeración y Accesorios, S.A. De C.V.
Carretera a Nogales 5577-A
Col. Rancho San Francisco C.P. 45090
Zapopan, Jalisco

ventas@reacsa.com.mx
www.reacsa.com.mx